

Fuzzy Logic Controller Replacing Two Level Flux Hysterises for DTC of IM for EV Applications

Radak Blange

Department of Electrical Engineering, North Eastern Regional Institute of Science & Technology,
Nirjuli-791109, Arunachal Pradesh
E-mail: rb@nerist.ac.in, radakblange@gmail.com

Abstract—The fossil fuels used by IC engine automobile are non-renewable as well as the excessive burning of these fossil fuels produces carbon monoxide thereby creating global warnings and environmental hazards. So the researchers have been actively exploring upon for producing Electric Vehicles (EV) which are clean and pollution free. EVs do not use fossil fuels but are powered from battery based electricity. EV uses electric motors and Induction Motor (IM) is one of the widely used motors for propelling EV systems and control of IM has been one of the emerging areas to study globally. Direct torque control (DTC) is one of the best and efficient methods of vector control for IM drives. But the conventional DTC-SVM uses two controllers- torque and flux hysteresis comparators to generate stator voltage vector which produces high torque ripples. To overcome these drawbacks, Fuzzy Logic Controllers (FLC) replacing the torque or the flux comparators or the both is one of the emerging and active research areas. In this paper, a design method for vector based DTC based on Fuzzy Logic Controller (FLC) replacing the Flux Hysteresis Block(FHB) have been developed and modeled in MATLAB-Simulink. The performance of electromagnetic behavior of the Conventional DTC based IM drive with using FLC have been evaluated and compared. The results of simulation indicated that the proposed FLC are better than that of conventional Flux Hysteresis. FLC based DTC easily tracks the reference torques, reduce the torque ripples and thereby improves the efficiency of Speed-torque of IM with faster responses which may be useful for fast changing torque as that of EV in any roads conditions. The proposed FLC algorithms are also simple and can be implemented easily with Fast DSP or FPGA platform or PIC Microcontroller.

Keywords:-Fuzzy Logic Controller, Induction Motor, Electric Vehicle(EV),Direct Torque Control(DTC),Space Vector Modulation(SVM) Matlab-Simulink, Torque Hysteresis, Flux Hysteresis.

1. INTRODUCTION

Broadly there are two types of Electric motors(EM), viz Alternating Current motors(AC Motors) and Direct Current Motor(DC Motor). AC Motors are preferred to DC Motor in many industrial Drives due to former being simple structure, cheaper, economical, rugged, reliable and has higher efficiency than the later when operated at high speed. Squirrel cage IM is one of the most commonly used ac motors in

electric vehicles. The squirrel cage IM are suitable for constant speed drives applications but with the evolution of power electronics converters, it has been made possible the use for wide range of variable speed drives application[1]. Due to the ruggedness, the IM can be operated directly from supply mains, but in order to achieve variable speed, a frequency converter is used between supply mains and motor[2]. IM can be controlled by scalar control(SC) also called open loop and vector Control(VC) also called closed loop techniques. VC controls the rotor flux and torque of the motor by estimating the speed and voltage. This estimation can be either directly done through measurements or indirectly through calculations [3]. VC made the ac drives equivalent to dc drives in the independent control of flux and torque and superior to dc drives in their dynamic performance[4]. Direct Torque Control(DTC) is one of the latest Vector Control for IM drives. DTC based IM drives uses feedback control of torque and stator flux which are computed from the measured value of stator voltages and stator currents[5]. The major disadvantage of the DTC drive is the steady state ripples in torque and flux due to which the accuracy of speed estimation is affected. To overcome or reduces the drawbacks of the conventional DTC drive with its two controllers, Use of Fuzzy Logic Controllers (FLC) substituting both the controllers blocks have bright scopes.

In this paper a Fuzzy Logic Controller based for Vector controller of IM replacing the Flux Hysteresis(FH) Block have been developed and modelled in MATLAB-Simulink Environment. For the ease of perception of the concept developed under this work, This paper is subdivided into sections. Section. II covers the basic theory of Vector Controller cum DTC scheme. Section. III covers the motor model, section. IV explains the Hysteresis Controllers and switching voltage vector, Section. V describes the Fuzzy Logic Control, Section VI covers the simulation results and finally Section VII covers the Conclusion Parts.

2. VECTOR CONTROL OF INDUCTION MOTOR.

The vector control of IM are of two types one being direct and other being indirect vector control. Direct Torque Control (DTC) is one of the direct vector control. The DTC method of IM uses feedback control of torque and stator flux computed from the measured value of stator voltages and stator currents[5]. For the ease of understanding of these statement, the block diagram of DTC of IM is shown in Fig. 1. The DTC method uses a stator reference model of the IM thereby avoiding the trigonometric operations in the co-ordinate transformations of the synchronous reference frames. This is one of the key advantages of the control scheme[6]. The scheme uses the hysteresis band to directly control the stator flux and torque of the IM. When the stator flux falls outside the hysteresis band, the inverter switching stator is changed so that the flux takes an optimal path toward the desired value[4]. The name direct torque control is derived from the fact that on the basis of the errors between the reference and the estimated values of torque and flux it is possible to directly control the inverter states in order to reduce the torque and flux errors within the prefixed band limits [2]. When the error is within acceptable level, no voltage is applied on the machine. Due to the absence of several controllers and the transformations in DTC, the delay in the processing signal is drastically reduced, further the control is exercised by instantaneous voltage vector in DTC. The major disadvantage of the DTC drive is the steady state ripples in torque and flux. The pulsations in flux and torque affect the accuracy of speed estimation. It also results in higher acoustical noise and in harmonic losses[7].

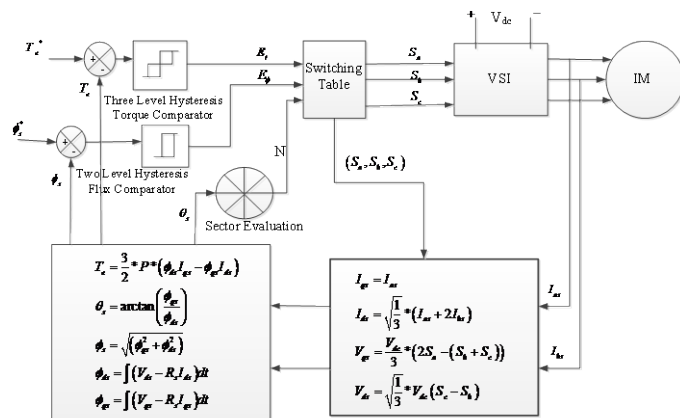

Fig. 1: Block Diagram of Direct Vector control based IM Drives.

3. INDUCTION MOTOR MODEL.

The Model of Induction Motor is represented by the following set of equations given (equations 1. 1 to 1. 7) where all quantities are referred as either with respect to stator or rotor. The three switching voltage vectors for the voltage source inverter (VSI) are considered as S_a, S_b, S_c from which we can obtain the direct(d) and quadrature(q) components of the stator voltages as follows:

$$V_{ds} = \left(\frac{1}{\sqrt{3}} \right) * V_{dc} (S_c - S_b) \tag{0.1}$$

$$V_{qs} = \left(\frac{V_{dc}}{3} \right) * (2S_a - (S_b + S_c)) \tag{0.2}$$

Where V_{dc} is the input dc voltage. The corresponding d and q components of fluxes with respect to stator is as follows:

$$\phi_{ds} = \int (V_{ds} - R_s I_{ds}) dt \tag{0.3}$$

$$\phi_{qs} = \int (V_{qs} - R_s I_{qs}) dt \tag{0.4}$$

The stator flux(ϕ_s), the developed electromagnetic torque(T_e) of IM and the shifted angle of (θ_s) are given by the following eqns.

$$\phi_s = \sqrt{(\phi_{qs}^2 + \phi_{ds}^2)} \tag{0.5}$$

$$T_e = \left(\frac{3}{2} \right) * P * (\phi_{ds} I_{qs} - \phi_{qs} I_{ds}) \tag{0.6}$$

$$\theta_s = \arctg \left(\frac{\phi_{qs}}{\phi_{ds}} \right) \tag{0.7}$$

Where P is the number of stator poles, I_{ds} and I_{qs} are the d and q components of stator current

4. HYSTERESIS CONTROLLER AND SWITCHING VOLTAGE VECTOR

The estimated torque and stator flux are compared to the reference torque(T_e^*) and reference flux(ϕ_s^*) respectively. From the fig. 1 is seen that the input to three level hysteresis comparator is nothing but the error T_e^* and estimated torque(T_e). Similarly the error between the reference stator flux magnitude ϕ_s^* and estimated stator flux magnitude ϕ_s is the input of a two level hysteresis comparator. Depending upon the output from torque hysteresis (TH) and flux hysteresis (FH) block, the switching states for the H-bridge inverters can be generated. On the basis of torque, flux increment and decrement at a particular value of flux sector, the corresponding voltage vector are generated. The increment or decrement of torque and flux determines voltage vector and their relations are shown in table. I[6]

Table I: Switching Voltage Vector for VSI.

E_ϕ	E_T	N=1	N=2	N=3	N=4	N=5	N=6
1	1	V6	V1	V2	V3	V4	V5
1	0	V7	V0	V7	V0	V7	V0
1	-1	V2	V3	V4	V5	V6	V1
0	1	V5	V6	V1	V2	V3	V4
0	0	V0	V7	V0	V7	V0	V7
0	-1	V3	V4	V5	V6	V1	V2

5. FUZZY LOGIC CONTROLLER REPLACING FHB

Fuzzy Logic Controller(FLC) have been a very active research area for effective for Controlling of Induction Motor drives in the recent years[8-10]. The conventional DTC-Space Vector Modulation(SVM) uses two PI controllers to generate the required reference stator vector but these methods have some drawbacks. These drawbacks are minimized by the used of FLC. Fuzzy based DTC by replacing one or both the PI controllers have been used which achieves a decoupling torque, stator flux control with low ripple with good performance with faster responses. [9-10,11]. In this paper, a design method for vector based DTC based on Fuzzy Logic Controller (FLC) replacing the Flux Hysteresis Block(FHB) have been developed and modeled in MATLAB-Simulink. The Block Diagram of Proposed Model is shown in Fig. 2. The fuzzy controller functional block for implementation is shown in Fig. 3.

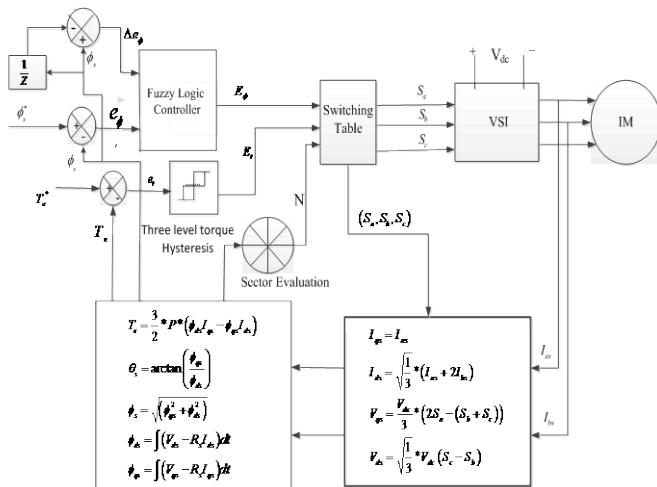

Fig. 2: Block Diagram of DTC with Proposed FLC based IM Drives

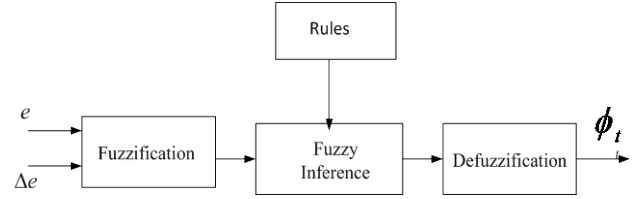

Fig. 3: Block Diagram of Fuzzy logic Controller

The FLC block as shown in Fig. 3 has two inputs and one output. The two input variables are error $e = \phi_{ref} - \phi_{actual}$ and change in Error $\Delta e = \phi_{present} - \phi_{previous}$ and the output variables is E_T . The input variables “change in error” and the output flux are converted to per units. The fuzzy membership functions (MF) of input variables and output variable Fig. 4, Fig. 5 and Fig. 6 respectively. Negative High(NH),Negative Medium(NM),Negative Low(NL) Zero(Z),Positive Low(PL),Positive Medium(PM), Positive High(PH),Very Very Low(VVL),Very Low(VL),Medium(M),High Medium(AM), High(H) and Very High(VH).

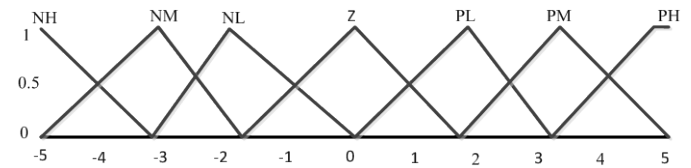

Fig. 4: MF of input variables “error”

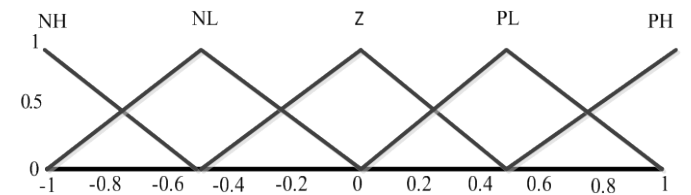

Fig. 5: MF of input variables “ Change in error”

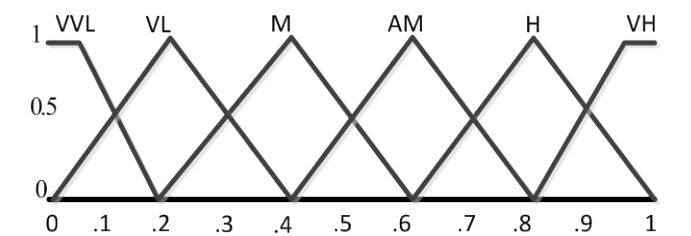

Fig. 6: MF of Output variables “ Flux”

The fuzzy control rules as given in Table-II was done with Mamdani Methods and the defuzzification was done with the centre of gravity method to calculate the output of flux.

TABLE II: Fuzzy Control Rules

Δe \ e	NH	NM	NL	Z	PL	PM	PH
NH	VVL	VVL	VVL	M	H	VH	VH
NL	VVL	VVL	VL	M	AM	H	VH
Z	VVL	VVL	VL	M	AM	AM	AM
PL	VL	VL	VL	M	AM	AM	H
PH	VL	VL	VL	AM	AM	AM	AM

Table III: Parameter of Induction Motor.

Parameters	Values
Voltages	415/220V
Pole Pair	1
R_s	4.61 Ω
R_r	7.548 Ω
L_s	0.022H
L_r	0.022H
M_{sr}	0.447H
J	0.01484kg/m ²

6. SIMULATION RESULTS

A simulation on developed model of the DTC IM with Fuzzy based flux control for EV drives was carried out using Matlab/simulink for a simulation time of 0.6 Seconds. The reference torque of the Motor was set at 3.725 N-m. The Motor used for the simulation and experiment is a standard 50 Hz,415/220V squirrel cage Induction motor and its parameters are given in the following table III. The simulations results are shown in fig. 7 and fig. 8.

The simulated results of DTC with fuzzy and without Fuzzy have been compared for analysis and performance evaluation. The comparisons of the results of DTC with fuzzy and without Fuzzy is provided in figure. 9 below.

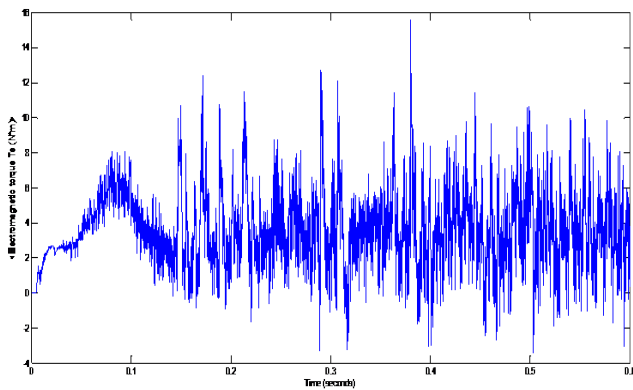

Fig. 7: Electromagnetics torques of IM with FHB and THB

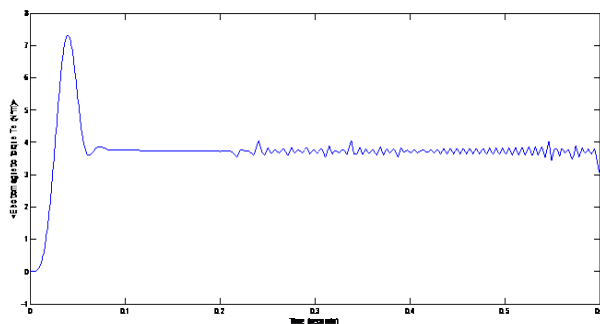

Fig. 8: Electromagnetics torques of IM with THB and Fuzzy Logic Controller replacing FBH.

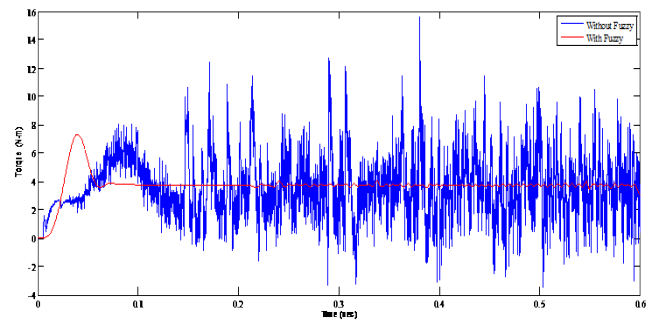

Fig. 9: Comparison of Electromagnetics Torques of IM for only FLC replacing FHB with THB and Without Fuzzy Logic Controller

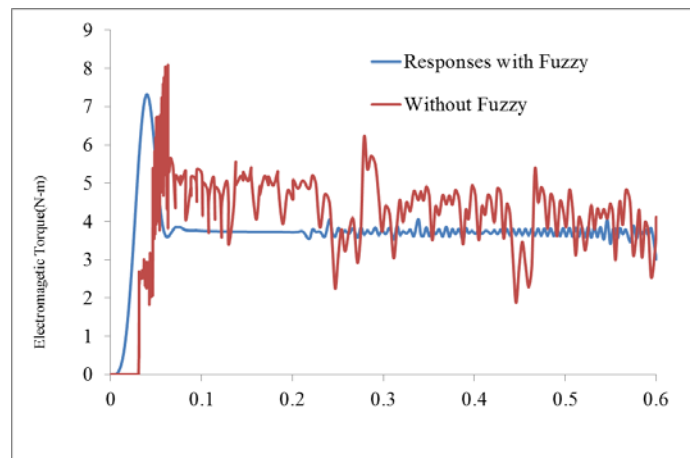

Fig. 9: Comparison of Electromagnetics Torques of IM for only FLC replacing FHB with THB and Without Fuzzy Logic Controller

7. CONCLUSION

In this paper, a design method for vector control based DTC of induction motor using Fuzzy Logic Controller replacing the Flux Hysteresis Block have been successfully developed and

modelled in MATLAB-Simulink. The performance of electromagnetic torque behavior of the motor model using FLC replacing FHB together with Torque Hysteresis and Conventional DTC(with THB & FHB) have been evaluated and compared. The results of simulation show that the proposed FLC for DTC provides better performance than that of conventional DTC technique. The Proposed FLC based DTC significantly and easily tracks the reference torques and flux thereby improves the efficiency of Speed-torque of IM with faster responses for fast changing torque as that of EV in any uneven roads conditions. The proposed FLC models are also simple and can be implemented easily with Fast DSP or Microcontroller or FPGA platform.

REFERENCES

- [1] M. Kazmierkowski, G. Buja, Review of direct torque control methods for voltage source inverter-fed induction motors, in IEEE conf. on Industrial Electronics Society , 2003, Vol. 1, pp. 981–991.
- [2] I. Takahashi, T. Noguchi, A new quick-response and high-efficiency control strategy of an induction motor, Industry Applications, IEEE Transactions on IA-22 (5) (1986) 820–827.
- [3] F. Blaschke, The principle of field orientation as applied to the new transvector closed loop system for rotating field machines, Siemens Review Vol. 39, no. 3 (May 1972) 217–220.
- [4] M. Depenbrock, Direct self-control (dsc) of inverter-fed induction machine, Power Electronics, IEEE Transactions on 3 (4) (1988) 420–429.
- [5] T. Ohtani, Torque control using the flux derived from magnetic energy in induction motors driven by static converter, in: Conf. Record of International Power Electronics Conference, March 1983, pp. 696–707.
- [6] R. Krishnan, Electric Motor Drives: Modeling, Analysis, and control, PHI Learning, 2010.
- [7] U. Senthil, B. G. Fernandes, Hybrid space vector pulse width modulation based direct torque controlled induction motor drive, in: Power Electronics Specialist Conference, 2003. PESC '03. 2003 IEEE 34th Annual, Vol. 3, 2003, pp. 1112–1117 vol. 3.
- [8] Turki Y. Abdalla et al” Direct Torque Control System for a three phase Induction Motor with Fuzzy Logic Based Speed Controller” 1st International Conference on energy, Power and Control (EPC-IQ) 2010.
- [9] Jose L. Azcue P et al. ”The DTC-SVM scheme with Takagi-Sugeno fuzzy controller for three phase IM” on 8th international conference of fuzzy systems and knowledge Discovery (FSKD) 2011
- [10] Joes L. Azcue et al” SFO-DTC Scheme with Fuzzy Controller for Asynchronous machine” on 4th international Conference on power, Energy and electric drives ,2013
- [11] Joes L. Azcue and Ernesto Ruppert “Three phase IM DTC-SVM scheme with self-tuning PI-Type Fuzzy controller” on 7th international conference of fuzzy systems and knowledge Discovery (FSKD) 2010